



Universal

Rolling shutter automation for industrial and residential use

- This 230V motor is available in a double motor with electro-brake, single motor with electro-brake or simply reversible without brake.
- Where needed the release system is included.
- The built-in limit switches easily allow setting the closing and opening positions.
- This item is a positive solution to automate new and old shutters, the double motor version suits for large size shutters (up to 360 Kg).



UNIVERSAL



UNIVERSAL B/2M



UNIVERSAL B

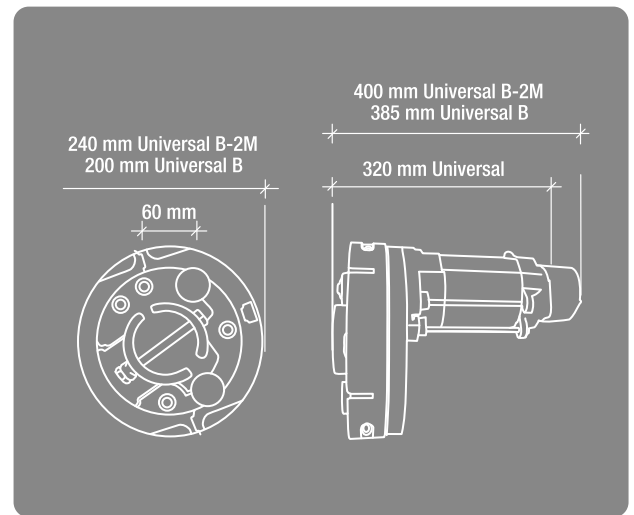

	UNIVERSAL	UNIVERSAL B	UNIVERSAL 2M
--	-----------	-------------	--------------

Power supply	V	230V~50/60Hz	230V~50/60Hz	230V~50/60Hz
Current	A	2,7	2,7	5,5
Motor power	W	600	600	1260
Thrust	Nm	178	178	443
Pulley speed	rpm	10	10	8
Max Load	Kg	170	170	360
Max stroke	m	6	6	6
Drive-shaft diameter	mm	60/48	60/48	76
Spring-holder pulley	mm	200/220	200/220	240
Duty cycle	%	30	30	30



Universal	230V	170 Kg
Universal B	230V	170 Kg
Universal 2M	230V	360 Kg

SCHEME ASSEMBLY

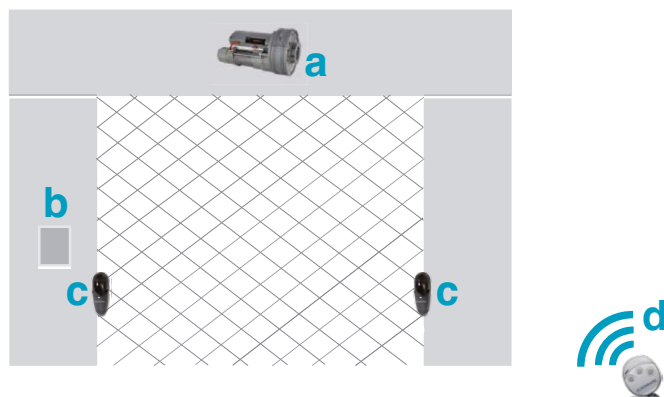

a motor	c photocells
b control unit	d transmitter

OPTIONAL ACCESSORIES



Photocells set
RF37



Transmitters
JEDI



Control unit
Q45



Key-switch
ELECTRO



Safe box
S004



YEARS OF WARRANTY



RELIABLE



SAFE



EASY TO INSTALL
EASY TO BE
PROGRAMMED